

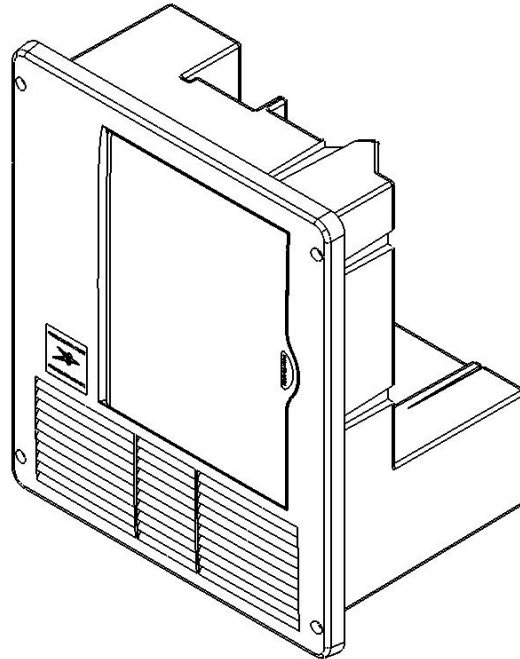

Installation and Operation Guide for PD4300 and PD4500 Series Power Control Centers

Extended warranties
are available for purchase at
www.progressivedyn.com



Thank you for selecting Progressive Dynamics as your choice for your RV power needs. We'd like to welcome you to a full line of industry leading and time tested products including our newest additions to the PDI family, the PD4300 and PD4500 Series POWER CONTROL CENTERS.

The PD4300 and PD4500 Series POWER CONTROL CENTERS offer break-through technologies that help maintain and lengthen the life of your batteries such as our patented Charge Wizard®.

The heart of the PD4300 and PD4500 is the INTELI-POWER Converter. The built-in Charge Wizard® microprocessor constantly monitors the battery voltage then automatically adjusts the converter output voltage to provide the proper charging voltage for fast recharges and long-term maintenance.

The intelligent way to charge and maintain your RV battery.

With enough AC and DC branches you'll have plenty of options for your growing RV needs.

Progressive Dynamics, Inc.

507 Industrial Rd.
Marshall, MI 49068
www.progressivedyn.com

Patent Numbers: 5,687,066 - 5,600,550 - 5,982,643 - 6,184,649 - 7,782,002

Table of Contents

Installation Instructions	1
Wiring Diagram	1
Features and Operating Instructions	2
The Charge Wizard	2
Reverse Battery Protection	2
Technical Specs and Troubleshooting	3-4

LIMITED WARRANTY

- I. **LIMITED WARRANTY:** Progressive Dynamics, Inc. warrants its power control center to be free from defects in material or workmanship under normal use and service; and limits the remedies to repair or replacement.
- II. **DURATION:** This warranty shall extend for a period of two years from the original date of purchase, and is valid only within the continental limits of the United States and Canada.
- III. **WARRANTY EXCLUSIONS:** This warranty specifically does not apply to:
- A. Any product which has been repaired or altered in any way by an unauthorized person or service station;
 - B. Damage caused by excessive input voltage, misuse, negligence or accident; or an external force;
 - C. Any product which has been connected, installed or adjusted or used other than in accordance with the instructions furnished, or has had the serial number altered, defaced or removed;
 - D. Cost of all services performed in removing and re-installing the power converter; and
 - E. ANY LOST PROFITS, LOST SAVINGS, LOSS OF USE OF ENJOYMENT OR OTHER INCIDENTAL DAMAGES ARISING OUT OF THE USE OF, OR INABILITY TO USE, THE PRODUCT. THIS INCLUDES DAMAGES TO PROPERTY AND, TO THE EXTENT PERMITTED BY LAW, DAMAGES FOR PERSONAL INJURY. THIS WARRANTY IS IN LIEU OF ALL OTHER WARRANTIES, INCLUDING IMPLIED WARRANTIES OF MERCHANTABILITY AND FITNESS FOR A PARTICULAR PURPOSE.
- IV. **PROOF OF PURCHASE:** A warranty claim must be accompanied by proof of the date of purchase.
- V. **CLAIM PROCEDURE:** Upon discovery of any defect, Progressive Dynamics, Inc. shall be supplied the following information at the address listed below:
- A. Name and address of the claimant;
 - B. Name and model of the product;
 - C. Name, year and model of the recreational vehicle in which the product was installed;
 - D. Date of purchase; and
 - E. Complete description of the claimed defect.

Upon determination that a warranty claim exists (a defect in material or workmanship occurring under normal use and service,) the converter section shall be shipped postage prepaid to Progressive Dynamics, Inc. together with proof of purchase. The product will be repaired or replaced and returned postage prepaid.

For Warranty Service Call: (269) 781-4241

Installation Instructions

The PD4300 and PD4500 series POWER CONTROL CENTERS may be installed vertically (converter section down) or horizontally (converter section to the right).

Unit is NOT ignition protected. Do not mount in the LP gas or the battery compartment.

The POWER CONTROL CENTER was not designed for wet or damp locations. Install in an interior / dry location.

The INTELI-POWER converters are not designed for zero clearance compartments.

Cut mounting hole to approximately 10 1/8" x 13 1/4".

Connect wiring system using appropriately sized cable clamp. A closure plug kit for any unused Romex connectors may be purchased from Progressive Dynamics, Inc. Part Number PD812374.

For installations without an external DC disconnect switch, connect battery POS (+) to the BATTERY POS. + lug and battery NEG (-) to the BATTERY NEG. - lug. The ALTERNATE BATTERY POS. + lug is not used. (see wiring diagram for component details)

DC DISCONNECT: For installations incorporating an external DC disconnect switch, connect battery POS (+) and the BATTERY POS. + lug to the same pole on the external disconnect switch. Remove the JUMPER. Connect the ALTERNATE BATTERY POS. + to the other pole on the external disconnect switch. (see wiring diagram for component locations)

The OEM should test the POWER CONTROL CENTER converter under full load conditions in its intended mounting location to ensure proper ventilation. A minimum compartment size of 3 cubic feet is recommended. Failure to provide adequate ventilation will prevent the converter from supplying full output power.

When used with a gel cell battery, install jumper (0.100" spacing, not supplied) to 2-pin connector at H4 on main circuit board.

Detailed Wiring Diagram

Note: Some factory installed wiring not shown for clarity

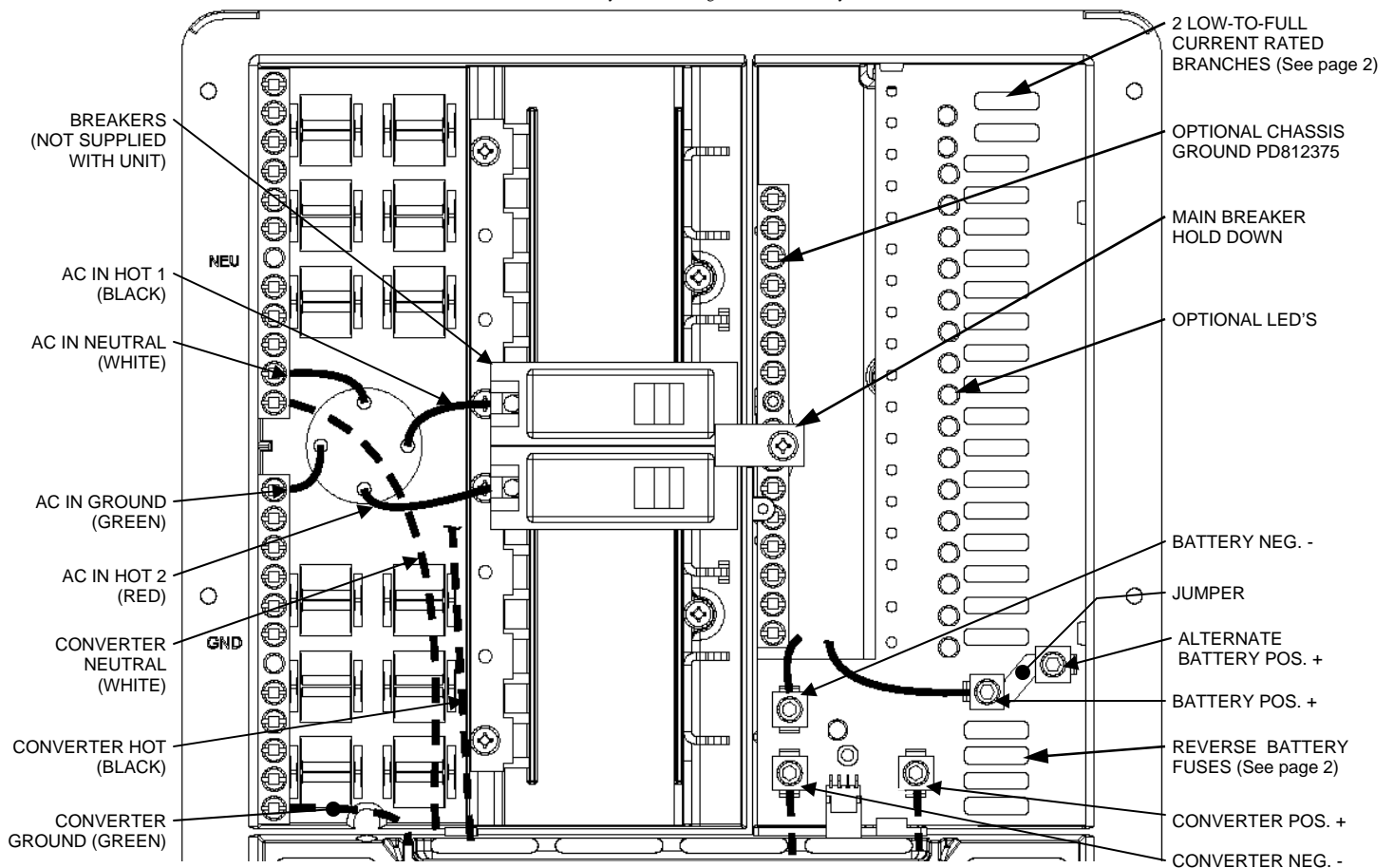

Note: Breakers are not supplied. Connect Converter Hot to an open breaker.

Note: Above image may vary, depending on model.

Consult a licensed electrician or an RV technician for installation assistance

User Information

Many options will be installed prior to the purchase of your new RV, however there are a few options that you should be aware of while operating your new POWER CONTROL CENTER.

The Charge Wizard[®] selects the best mode for your battery automatically. However, you can temporarily override the auto settings giving you the freedom to change the way your battery charges. The Charge Wizard[®] will be able to select between three very unique modes of battery charging. BOOST, NORMAL, and STORAGE.

BOOST MODE: If the converter senses that the battery voltage has dropped below a preset level the output voltage is increased to approximately 14.4 volts DC to rapidly recharge the battery.

NORMAL MODE: Output voltage set at approximately 13.6 volts DC.

STORAGE MODE: When the converter senses that there has been no significant battery usage for 30 hours the output voltage is reduced to 13.2 volts DC for minimal water usage. When in storage mode the microprocessor automatically increases the output voltage to 14.4 volts DC for 15 minutes every 21 hours to help reduce sulfation of the battery plates.

-The above modes can be manually selected by pressing the Wizard Mode Button in the front panel.-
- All times and voltages provided above are approximate. -

CAUTION

IT IS IMPORTANT THAT THE FLUID LEVEL OF ANY CONNECTED BATTERIES BE CHECKED ON A REGULAR BASIS. ALL BATTERIES WILL "GAS" AND LOSE SOME FLUID WHEN CONTINUOUSLY CONNECTED TO ANY CHARGING SOURCE.

The Charge Wizard[®] Operation

While the built-in Charge Wizard[®] automatically determines which operating mode is best suited to recharge or maintain optimum battery condition, the **Wizard Mode Button** allows for manual override and has indicator light(s) to indicate the mode of operation.



NOTE: The Green LED on the left refers to the Charge Wizard[®] - the Red LED on the right was for the Charge Sentinel (supplied on converters built prior to year 2000)

BOOST MODE – Indicated by green LED remaining on. The output voltage is 14.4VDC to rapidly recharge the battery up to 90% of full charge.

NORMAL MODE – When the battery is between 50% and 90% charged, the green LED will flash once per second. When the battery has reached 90% of full charge the green LED will flash 2 - 3 times per second. In this mode the output voltage is 13.6VDC and the converter is safely completing the charge of the battery.

STORAGE MODE – Indicated by green LED flashing every 6 - 8 seconds. In this mode the output voltage has been lowered to 13.2VDC, the RV battery is fully charged and the converter is maintaining the charge.

MANUAL BUTTON - The manual button has been provided to allow the operator to temporarily override the converter (not recommended) or to verify the converter is operating properly. For manual operation, Press and Hold the button. The indicator light will soon remain "ON" indicating Boost Mode. Continue to hold the button and the light will blink rapidly indicating the converter is in the Normal Mode. Continue to hold the button until the light blinks slowly indicating the converter is now in the Storage Mode. After the manual button is released the converter will stay in the selected mode. When the battery charge status changes, the converter will return to the automatic mode of operation to prevent damage to the battery.

- All times and voltages provided above are approximate. -

REVERSE BATTERY PROTECTION CIRCUIT

If a battery is accidentally hooked up backwards, the converter will be protected. Easily accessible ATC type fuses will blow when a battery is connected in reverse. Replace with same type and rating.

Amp/Model	# of fuses	Fuse size (amps)
45	2	30
60	3	25
90	4	25

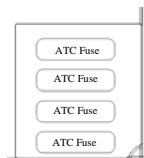

The DC Section:

The DC panel features up to 18 positions, rated for up to 30A, for accessories including two low-to-full current rated branches. These can be used for lower current devices such as smoke and CO detectors. Each branch has an optional LED light that indicates which fuse has blown.

See product labeling for actual DC fuse position ratings.

CAUTION

FOR CONTINUED PROTECTION AGAINST RISK OF FIRE OR ELECTRICAL SHOCK,
REPLACE ONLY WITH SAME TYPE AND RATING FUSE.

Specifications (Specifications subject to change without notice)			
Model	PD4345 / PD4545	PD4360 / PD4560	PD4590
AC Section (PD4500)	240/120 VAC 50A Maximum Input 120 VAC 50A Maximum Output - 12 Branch Circuits Max.		
AC Section (PD4300)	120 VAC 30A Max. - 7 Branch Circuits Max.*		-
DC Section	12 VDC 60A Max.	12 VDC 80A Max.	12 VDC 100A Max.
Converter Section	Input: 105-130 VAC 50/60 Hz 725 Watts Output: 13.6 VDC, 45 Amps Weight: 8 lbs	Input: 105-130 VAC 50/60 Hz 1000 Watts Output: 13.6 VDC, 60 Amps Weight: 8 lbs	Input: 105-130 VAC 50/60 Hz 1550 Watts Output: 13.6 VDC, 90 Amps Weight: 10 lbs

* Consult local regulatory authority for possible branch circuit restrictions

Breakers: Recommended breakers rated maximum 50A for PD4500 series and 30A for PD4300 series

The following breakers are suitable for MAIN and BRANCH breakers	50 Amp MAIN	30 Amp MAIN	45/60 Amp Converter Branch	90 Amp Converter Branch	Filler Plate
ITE/Siemens—QP,QT					
Thomas & Betts—TB & TBBD Series					ITE/Siemens QF3
Square D—HOM, HOMT	50A Dual	30A	15A	20A	GE TQLFPI
Cutler Hammer/Bryant—BR,BRD Series					
GE—HACR					

TROUBLE SHOOTING GUIDE

<u>PROBLEM</u>	<u>POSSIBLE CAUSES</u>	<u>ACTION</u>
No Output	120 VAC supply not connected	Connect power supply Check AC distribution panel for proper operation
	Reverse battery fuses blown (See page 1 for location)	Check for reverse battery connection. Replace fuses with same type and rating (See page 2)
	Short circuit	Trace RV circuits for possible fault
	Unit has shutdown due to overheating	Check air flow Allow unit to cool
	Unit has shutdown due to over voltage (Converter will shut down if the input voltage exceeds 132 VAC)	Check input voltage Correct input voltage
	Low Output	Compartment gets too hot
Excessive load for converter		Reduce load requirements or install larger converter
Input voltage not between 105-130 VAC		Correct input supply voltage
Bad battery cell(s)		Replace battery
Intermittent or no Output on Generator, works on Shore Power	Unit has shutdown due to over voltage.	Add another load to the generator, this may reduce the “spikes” to an acceptable level
	Some generators exhibit excessive voltage spikes on the AC power output, this may cause the over voltage protection to shut the unit down	Contact generator manufacturer for possible defect in the generator
Open Fuse Indicator (See page 1 for location)	Fuse open.	Replace fuse with same type and rating.

Consult a licensed electrician or an RV technician for installation assistance

Do not replace the converter section unless the following checks have been performed:

1. Use an AC voltmeter to check for the proper voltage at the 120 VAC breaker that the converter is connected to. This voltage should be between 105 and 130 volts.
2. Remove the reverse battery fuses and check the converter output from the CONVERTER GND to the CONVERTER POS terminals on the DC board. This should be 13.6 VDC.
3. Check the Reverse Battery fuses . These fuses will only blow if the battery or DC output leads were connected in reverse, even for a moment. If they are blown check the polarity of the battery connections before replacing them.
4. If the Converter output is not present and there is AC to the converter , the converter is defective.

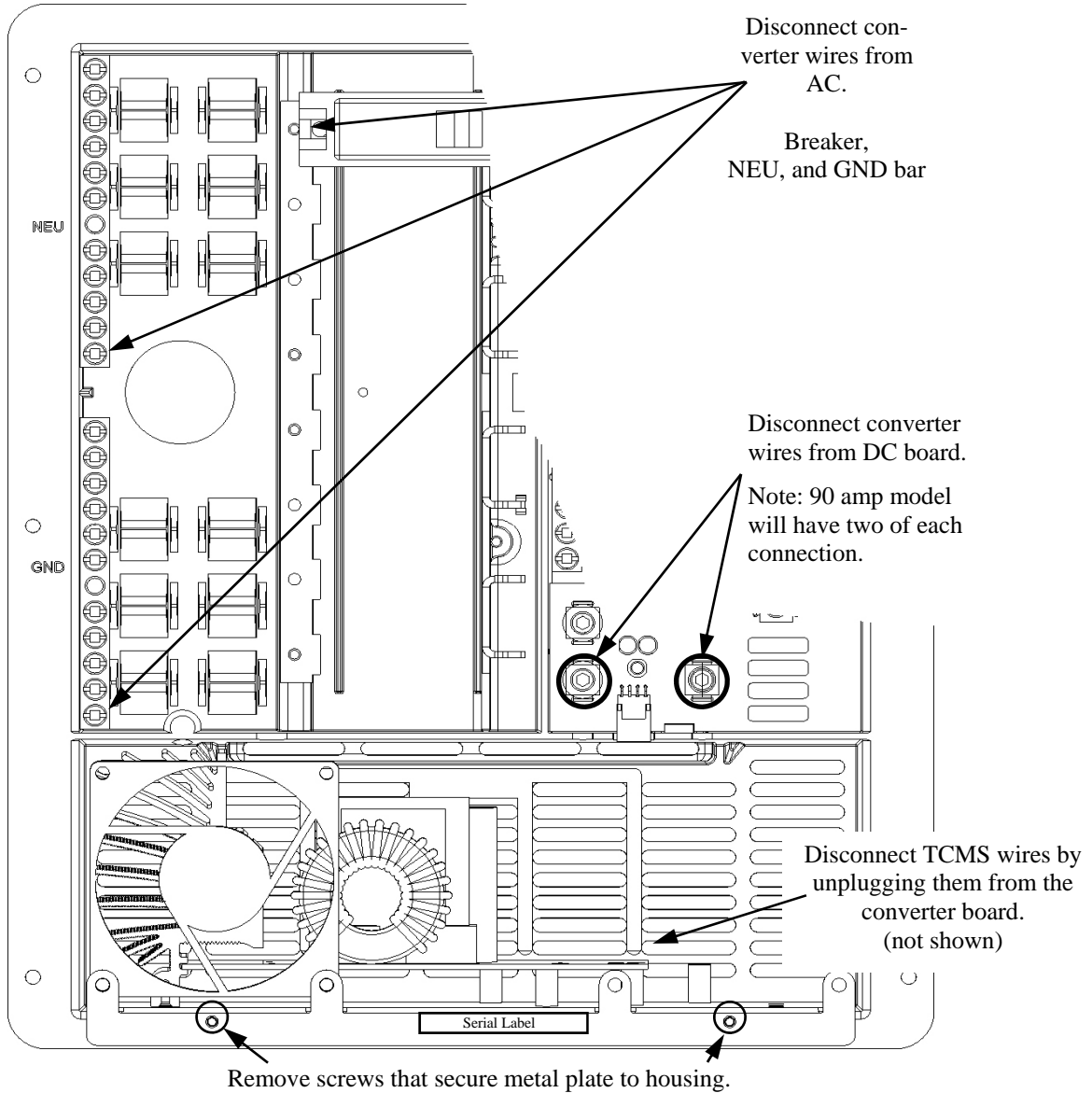

If you should need to replace the power converter for any reason, follow these steps to safely remove the converter section.

Make sure all power is disconnected before proceeding.

1. Remove the neutral, ground, and breaker wires that lead to the converter on the AC side.
2. Remove the converter output wires from the DC side, ground and positive. (90A model will have two each)
3. Make sure you unplug the TCMS wiring harness before moving on to the next step.
4. Finally unscrew the two screws that hold the metal converter plate to the plastic housing.

For repairs, only send the converter section.

Make sure you use proper packaging to ensure the product's safe arrival.

Notes:

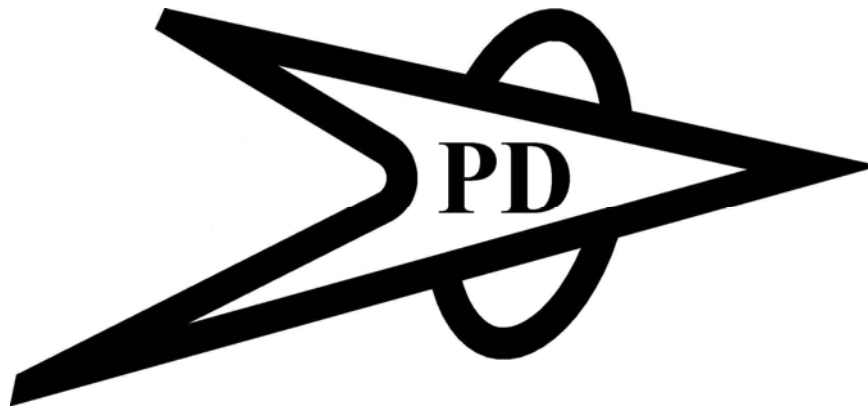

Progressive Dynamics, Inc.

507 Industrial Rd
Marshall, MI 49068

Visit us on the web for other great products.

www.progressivedyn.com